

# Flow Transmitter / Switch OMNI-RR..32

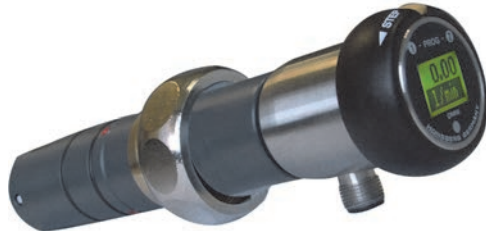

- Simple and economical flow meter for piping diameters from 32 mm to 150 mm
- Made from plastic (optionally stainless steel)
- With tapping sleeve fixing for very rapid installation Retro-fitting also easily possible
- Analog output 4..20 mA or 0..10 V
- Two programmable switches
- Graphical LCD display, backlit, can be read in sunlight and in the dark
- Selectable units in the display
- Programmable parameters via rotatable, removable ring (programming protection)
- Electronics housing with non-scratch, chemically resistant glass
- Rotatable electronic housing for best reading position

## Characteristics

The flow meter consists of a spinner which is rotated by the flow speed. The rotational speed is proportional to the flow rate. The rotational speed can be recorded using various sensor systems, depending on the different materials for the housing. With plastic housings, there are no magnets in the flow space.

The OMNI transducer located on the sensor has a backlit graphics LCD display which is very easy to read, both in the dark and in bright sunlight. The graphics display allows the presentation of measured values and parameters in a clearly understandable form. The measured values are displayed to 4 places, together with their physical unit, which may also be modified by the user. The electronics have an analog output (4..20 mA or 0..10 V) and two switching outputs, which can be used as limit switches for monitoring minimal or maximal, or as two-point controllers. The switching outputs are designed as push-pull drivers, and can therefore be used both as PNP and NPN outputs. Exceeding limit values is signalled by a red LED which is visible over a long distance, and by a cleartext in the display.

The stainless steel case has a hardened non-scratch mineral glass pane. It is operated by a programming ring fitted with a magnet, so there is no need to open the operating controls housing, and its leakproofness is permanently ensured.

By turning the ring to right or left, it is simple to modify the parameters (e.g. switching point, hysteresis...). To protect from unintended programming, it can be removed, turned through 180 ° and replaced, or completely removed, thus acting as a key.

**OPTION C:**  
 Preset Counter with external reset option, complementary switching outputs and actual value display.

**OPTION C1:**  
 Instantaneous value display with analogue output, pulse-volume output and totalizer

## Technical data

<b>Sensor</b>	OMNI-RR1	inductive sensor
	OMNI-RRH	hall sensor
<b>Nominal widths</b>	DN 32..150	
<b>Mechanical Connection</b>	welded-on nozzle, DN 50..150 tapping sleeve, DN 32..150 glue socket, Screw-in probe	
<b>Metering range</b>	15..1000 l/min for details, see table "Ranges"	
<b>Measurement accuracy</b>	±5 % of full scale value	
<b>Repeatability</b>	±1 % measured value	
<b>Medium temperature</b>	0..60 °C, type RRH as screw-in probe or with welded-on nozzle 0..95 °C	
<b>Pressure resistance</b>	PN 10 bar	
<b>Pressure loss</b>	typically < 0.1 bar	
<b>Materials medium-contact</b>		
Housing	PVC	1.4305
Tapping sleeve	PP	PP
Rotor	PVDF / 1.4310 or Titanium	PVDF / Magnets
Bearing	Iglidur X	Iglidur X
Axis	Ceramic ZrO2-TZP	Ceramic ZrO2-TZP
Seal	FKM	FKM
<b>Materials, non-medium-contact</b>	Electronics housing	stainless steel 1.4305
	Glass	mineral glass hardened
	Magnet	samarium-Cobalt
	Ring	POM
<b>Supply voltage</b>	18..30 V DC	
<b>Power consumption</b>	< 1 W	
<b>Analog output</b>	4..20 mA / max. load 500 Ω or 0..10 V / min. load 1 kΩ	
<b>Switching output</b>	transistor output "push-pull" (resistant to short circuits and polarity reversal) I <sub>out</sub> = 100 mA max.	
<b>Hysteresis</b>	adjustable, position of the hysteresis depends on minimum or maximum	

**Product Information**

**Sensors and Instrumentation**

<b>Display</b>	backlit graphical LCD-Display (transreflective), extended temperature range -20..+70 °C, 32 x 16 pixels, background illumination, displays value and unit, flashing LED signal lamp with simultaneous message on the display.
<b>Electrical connection</b>	for round plug connector M12x1, 5-pole
<b>Ingress protection</b>	IP 67 / (IP 68 when oil-filled)
<b>Conformity</b>	CE

**Wiring**

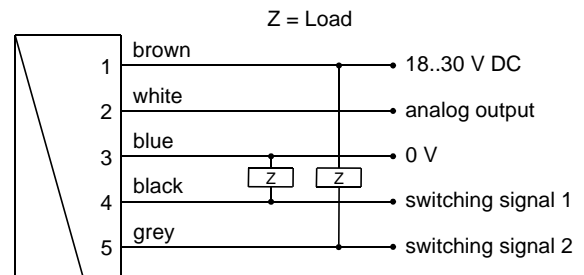

Connection example: PNP NPN

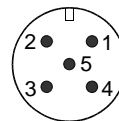

connector M12x1

See separate wiring at C and C1 option in the separate descriptions.

Before the electrical installation, it must be ensured that the supply voltage corresponds to the data sheet. The use of shielded cabling is recommended.

**Signal output curves**

Value x = Begin of the specified range

= not specified range

Current output

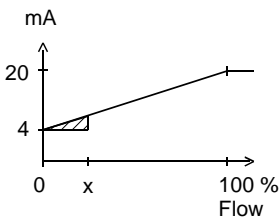

Voltage output

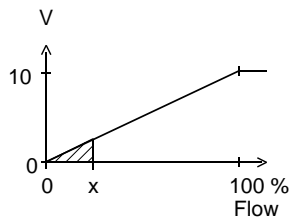

Other characters on request.

**Ranges**

Nominal width	Metering range l/min H <sub>2</sub> O	Q <sub>max</sub> l/min
DN 32	15.. 200	220
DN 40	15.. 300	360
DN 50	25.. 400	480
DN 65	40.. 500	600
DN 80	50.. 700	840
DN 100	85..1000	1200

The measured values were determined using a standing sensor in a flow of water from left to right at 25 °C and with 10 x D run-in and run-out sections.

**Dimensions**

Connection: tapping sleeve with piping section and glue socket(s) RR.-032MH...

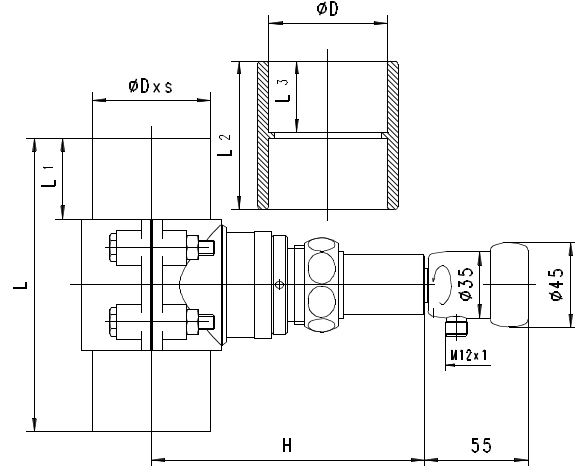

Nominal width	Type	ØD	s	H	L	L1	L2	L3
DN 32	RR.-032MH032.	40	1.9	145.0	132	31	55	26
DN 40	RR.-032MH040.	50	2.4		142	36	65	31
DN 50	RR.-032MH050.	63	3.0		156	43	79	38
DN 65	RR.-032MH065.	75	3.6	153.5	178	49	92	44
DN 80	RR.-032MH080.	90	4.3	156.0	202	56	107	51
DN 100	RR.-032MH100.	110	5.3	166.0	232	66	128	61
DN 125	RR.-032MH125.	140	6.7	172.0	287	81	159	76
DN 150	RR.-032MH150.	160	7.7	180.0	312	91	180	86

**Product Information**

**Sensors and Instrumentation**

Connection: tapping sleeve RR.-032BB... (optionally)

Connection: welded-on nozzle RR.-032VK000. (optionally)

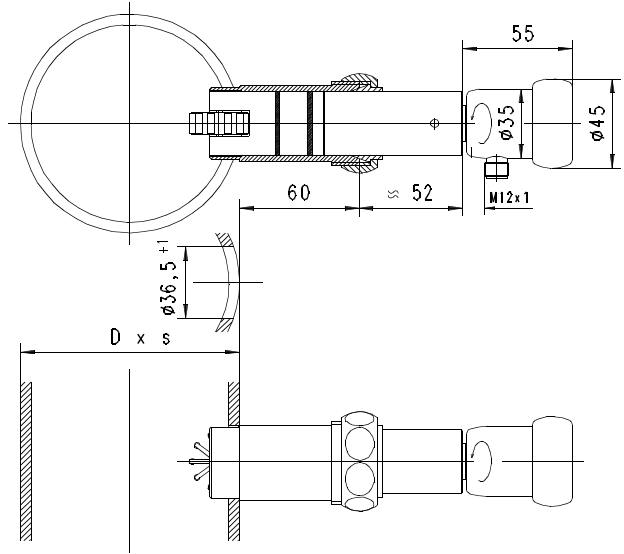
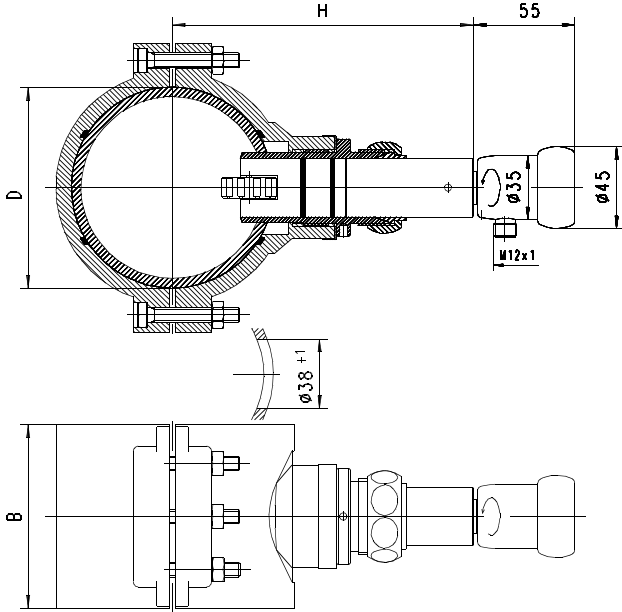

Nominal width	Type	D	B	H
DN 50	RR.-032BB050.	63	70	145.0
DN 65	RR.-032BB065.	75	80	153.5
DN 80	RR.-032BB080.	90	90	156.0
DN 100	RR.-032BB100.	110	100	166.0
DN 125	RR.-032BB125.	140	125	172.0
DN 150	RR.-032BB150.	160	130	180.0

**Gooseneck option**



A gooseneck (optional) between the electronics head and the primary sensor provides freedom in the orientation of the sensor. This option simultaneously provides thermal decoupling between the two units.

Connection: screw-in probe RR.-032RM000.  
 Provided by customer

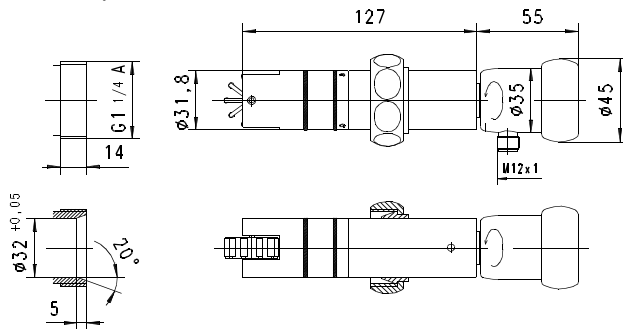

**Handling and operation**

**Installation**

The flow meters are inserted in probe form in a tapping sleeve, and are marked with the correct insertion depth. The installation direction of the probe is lengthways to the spinner, and is indicated with arrows on the front of the flow meter. An angular deviation of  $\pm 3^\circ$  has no effect on the measurement. The sensor must be installed with run-in and run-out sections of  $10 \times D$  of the pipe diameter, in order to prevent vortices and turbulence.

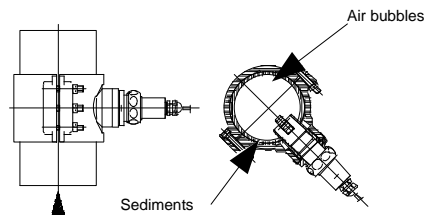

The best installation position (low contamination, good venting) is with the direction of flow from bottom to top, or in horizontal piping with the sensor at an angle of  $45^\circ$  downwards. The union nut must be tightened to a torque of 30 Nm.

**Product Information**

**Sensors and Instrumentation**

**Programming**

The annular gap of the programming ring can be turned to positions 1 and 2. The following actions are possible:



**Set to 1 = continue (STEP)  
 Set to 2 = modify (PROG)**

**Neutral position between  
 1 and 2**

The ring can be removed to act as a key, or turned through 180 ° and replaced to create a programming protector. Operation is by dialog with the display messages, which makes its use very simple.

Starting from the normal display (present value and unit), if 1 (STEP) is repeatedly selected, then the display shows the following information in this order:

**Display of the parameters, using position 1**

- Switching value S1 (switching point 1 in the selected unit)
- Switching characteristic of S1  
 MIN = Monitoring of minimum value  
 MAX = Monitoring of maximum value
- Hysteresis 1 (hysteresis value of S1 in the set unit)
- Switching value S2
- Switching characteristic of S2
- Hysteresis 2
- Code  
 After entering the **code 111**, further parameters can be defined:
- Filter (settling time of the display and output)
- Physical unit (Units)
- Output: 0..20 mA or 4..20 mA
- 0/4 mA (measured value corresponding to 0/4 mA)
- 20 mA (measured value corresponding to 20 mA)

For models with a voltage output, replace 20 mA accordingly with 10 V.

**Edit, using position 2**

If the currently visible parameter is to be modified:

- Turn the annular gap to position 2, so that a flashing cursor appears which displays the position which can be modified.
- By repeatedly turning to position 2, values are increased; by turning to position 1, the cursor moves to the next digit.
- Leave the parameter by turning to position 1 (until the cursor leaves the row); this accepts the modification.
- If there is no action within 30 seconds, the device returns to the normal display range without accepting the modification.

The limit switches S1 and S2 can be used to monitor minimal or maximal.

With a minimum-switch, falling below the limit value causes a switchover to the alarm state. Return to the normal state occurs when the limit value plus the set hysteresis is once more exceeded.

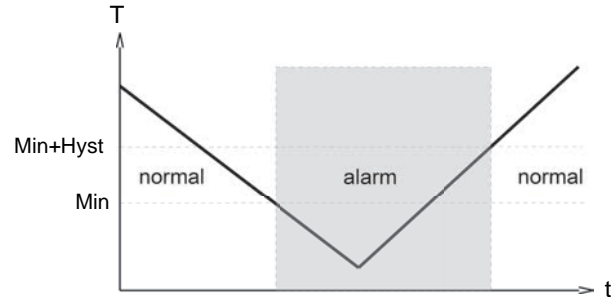

With a maximum-switch, exceeding the limit value causes a switchover to the alarm state. Return to the normal state occurs when the measured value once more falls below the limit value minus the set hysteresis.

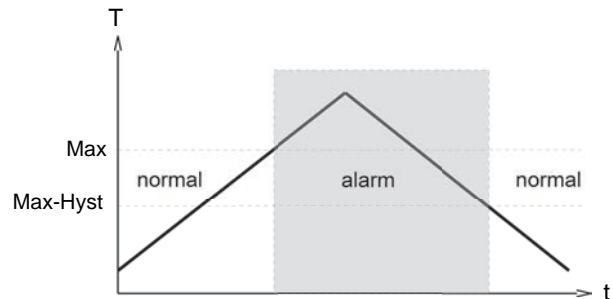

The change to the alarm state is indicated by the integrated red LED and a cleartext in the display.

While in the normal state the switching outputs are at the level of the supply voltage; in the alarm state they are at 0 V, so that a wire break would also display as an alarm state at the signal receiver.

**Overload display**

Overload of a switching output is detected and indicated on the display ("Check S 1 / S 2"), and the switching output is switched off.

**Simulation mode**

To simplify commissioning, the sensor provides a simulation mode for the analog output. It is possible to create a programmable value in the range 0..26.0 mA at the output (without modifying the process variable). This allows the wiring run between the sensor and the downstream electronics to be tested during commissioning. This mode is accessed by means of **Code 311**.

**Factory settings**

After modifying the configuration parameters, it is possible to reset them to the factory settings at any time using **Code 989**.

**Product Information**

**Sensors and Instrumentation**

**Ordering code**

The basic device is ordered e.g. RRI-032...  
with electronics e.g. OMNI-RRI-032...

RR  1.  2. **032**  3.  4.  5.  6.  7.  8. **E**

OMNI-RR  9.  10.  11. **S**  12.  13.

○=Option

<b>1. Sensor</b>					
I	with inductive sensor				•
H	with Hall sensor				•
<b>2. Union nut</b>					
032	G 1 1/4				
<b>3. Mechanical connection</b>					
MH	tapping sleeve with piping section and PVC glue sockets				
BB	PP tapping sleeve				•
RM	screw-in probe G 1 1/4 with clamping ring and union nut				•
VK	welded-on nozzle 1.4305				•
<b>4. Material for probe</b>					
H	PVC				•
K	stainless steel 1.4305				•
<b>5. Nominal width</b>					
000	screw-in probe / Welded-on nozzle				• •
032	DN 32				•
040	DN 40				•
050	DN 50				• •
065	DN 65				• •
080	DN 80				• •
100	DN 100				• •
125	DN 125				• •
150	DN 150				• •
<b>6. Seal material</b>					
V	FKM				
E	EPDM				•
N	NBR				•
<b>7. Rotor</b>					
10K	with 10 stainless steel clamps (RRI)				•
10T	with 10 titanium clamps (RRI)				•
05M	with 5 magnets (RRH)				•
<b>8. Connection for</b>					
E	electronics				•
<b>9. Sensor</b>					
I	with inductive sensor				•
H	with Hall sensor				•

<b>10. Analog output</b>			
I	current output 0/4..20 mA		•
U	voltage output 0/2..10 V		•
K	without		•
<b>11. Electrical connection</b>			
S	for round plug connector M12x1, 5-pole		
<b>12. Option 1</b>			
H	gooseneck model		
	tropical model		
O	oil-filled version for heavy duty or external use		
<b>13. Option 2</b>			
C	Counter C		
C1	Counter C1		

**Options**

Counter C (hardware and software option):  
Preset Counter with external reset option, complementary switching outputs and actual value display (modified wiring diagram!)

Counter C1 (software option):  
Instantaneous value display with analogue output, pulse-volume output and totalizer

**Accessories**

- Cable/round plug connector (KB...) see additional information "Accessories"
- Device configurator ECI-1